



CAROUSEL FEEDER

CAUTION

Read carefully all operating instructions and warnings (and warning decals) for your JUGS Carousel Automatic Feeder and your JUGS Pitching Machine before using. Call the factory at 1-800-547-6843 (in Oregon or outside the United States call collect 503-692-1635) for additional copies of all instructions if necessary.

The JUGS Carousel Automatic Feeder and JUGS Pitching Machine must be used only under supervision of persons instructed in the proper use of the feeder and machine. Do not allow children to operate feeder or machine.

Always keep hands away from the tires.

Always check tightness of all bolts and screws.

Check for frayed or damaged power cords. Use only properly grounded three-wire extension cords.

The feeder and machine must be used on a level surface.

A JUGS protective screen must be used to prevent possible damage to the feeder by a batted ball.

Once the feeder is loaded and positioned properly for use, again check and make sure that no one is in front of the machine or anywhere near the line-of-flight of the pitch your machine is set to throw. Then turn your pitching machine on making sure first the machine is set to throw at the desired target.

Make sure the feeder elbow is properly attached to the feeder chute on your machine and sitting correctly under the drop extrusion on the feeder.

The batter should then properly position themselves, ready for the pitch to be thrown. Only at that time should the feeder be turned on.

WARNING

Failure to read this warning and follow these **IMPORTANT SAFETY PRECAUTIONS** can result in **SERIOUS INJURY OR DEATH.**

If the red light is on, the feeder is on. If the feeder is on and the red light is not on, stop using the feeder immediately and call for service: 1-800-547-6843.

Always make sure that the main feeder body is empty of balls before approaching the front of the machine.

Never walk in the path of on-coming pitches.

When filling or refilling the feeder with balls, make sure the feeder and pitching machine are turned off and machine tires have come to a complete stop.

If feeder or pitching machine is hit by the ball, hitter must step out and take a pitch to verify that machine is still throwing strikes. Adjust pitching machine if necessary.

Before pitch elevation, location or type of pitch is changed, turn off feeder and pitching machine. Reposition feeder accordingly for smooth delivery.

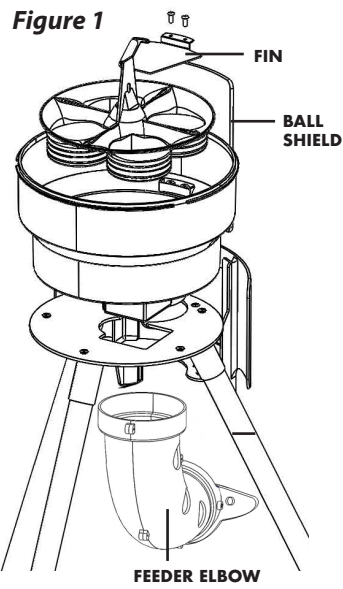

JUGS CAROUSEL FEEDER COMES WITH:

- FEEDER LEGS (3)
- TOP ASSEMBLY
- FEEDER ELBOW

OPERATING INSTRUCTIONS

1. Feeder Elbow Installation:

Remove both old Feeder Chute Mount Bolts (3) from the mini3, (Figure 2a.) Attach mini3 Feeder Elbow (Figure 2b) using the removed Feeder Chute Mount Bolts.

2. Three-Piece Leg Installation and Adjustment:

Press pin at top of each leg and insert into feeder base until pin engages hole (Figure 3.) Untighten the leg knobs (Figure 4) and adjust each leg for the desired height of your machine—Approximately 1/2" above the upper lip of the elbow (you will lower into the correct height when feeder is in proper position over elbow).

3. Drop Hole and Elbow Installation:

Position the feeder so that the drop extrusion sits directly over the elbow (figure 5) opening and using leg knobs, lower feeder to approximately 1/2" (13mm) below the top lip of the elbow (Figure 6.) **The feeder elbow does not attach to the feeder extrusion—it sits below it unattached.**

IMPORTANT: Do not allow the extrusion to rest on the elbow's bottom lip. There should be no direct weight of the feeder exerted onto the top of the elbow (Figures 7-10.)

4. Ball Usage:

With the machine and feeder turned off, place up to 18 softballs or 36 baseballs in the feeder's main body. With the softball feeder, use only 11- or 12-inch (circumference) regulation weight JUGS Practice Softballs with seams, LeatherLast™, Softie®, or Dimpled Style Softballs. DO NOT use any other type of ball in the feeder. With the baseball feeder, use only 9-inch (circumference) regulation JUGS Practice Baseballs with seams, Pearls®, Softie®, or Dimpled Style. DO NOT use any other type of ball in the feeder.

Check the condition of each ball every time before using them in the feeder or the machine. Out-of-round, cracked, soft, mushy or wet balls, or balls damaged or worn in any manner, will not work properly in the feeder and MUST NOT BE USED. Use only one type of ball at a time (i.e., seam, dimpled).

5. On/Off:

With your machine running and adjusted within the strike-zone, have the hitter step in and prepare to hit. Turn on feeder switch located on the underside of the unit. A red light appears when the feeder is on and the carousel is rotating (figures 11.) Balls will drop and exit the machine approximately every six seconds.

6. Reloading:

Always turn off the feeder and pitching machine when the feeder is empty. Disconnect power source to the ball feeder first, before turning off the power to the pitching machine. Once power to both the feeder and the pitching machine have been disconnected, visually check the feeder and the pitching machine to make absolutely sure they both are completely empty and the pitching machine wheel (or wheels) have come to a complete stop. Then, and only then should you load or reload the feeder or walk in front of the pitching machine, or anywhere close to the line-of-flight of the pitched ball. Stand to the side of the pitching machine when reloading balls.

TROUBLESHOOTING

• Stuck Balls:

On the rare occasion that a ball sticks, turn off the feeder and pitching machine and carefully dislodge ball.

• Softballs Do Not Fit Under the Fin:

If softballs won't fit under the fin as the carousel rotates, the baseball fin is most likely in place. Turn off the feeder and pitching machine and exchange fins (Figure 1.)

• Two or More Baseballs Fall Through the Drop Hole:

This is most likely caused by the incorrect fin size—softball vs. baseball. Turn off the feeder and pitching machine and exchange fins (Figure 1.)

NOTE: if feeder is set up properly, the ball should drop through the drop hole and smoothly travel through the feed chute—not "rattling" or ricocheting back and forth down the chute. If set up correctly, the ball will drop in one perfect swoop through the elbow, chute then tire. This is essential for timing the pitch as a hitter.

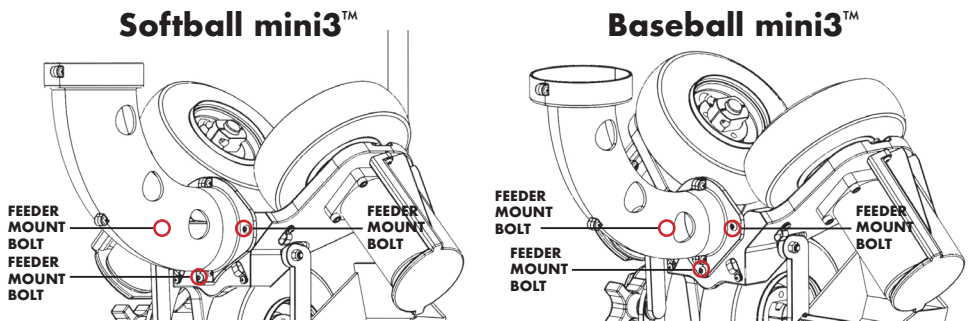
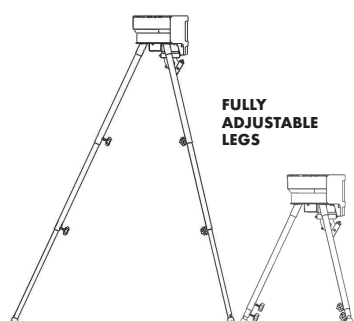
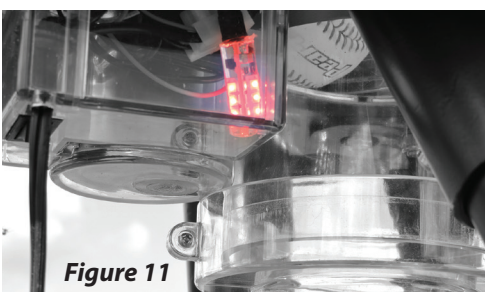
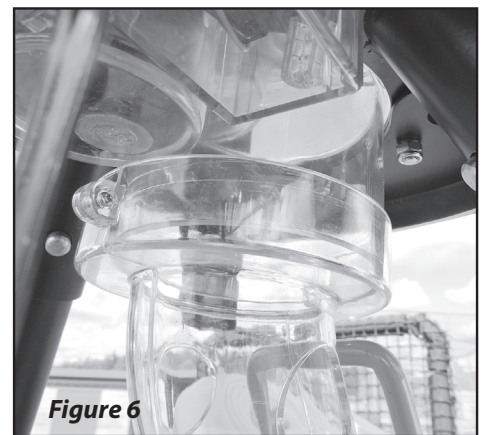
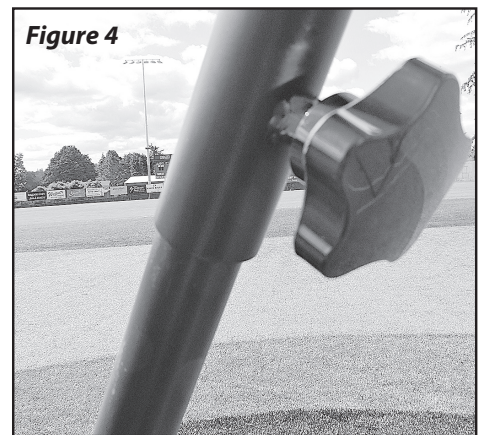
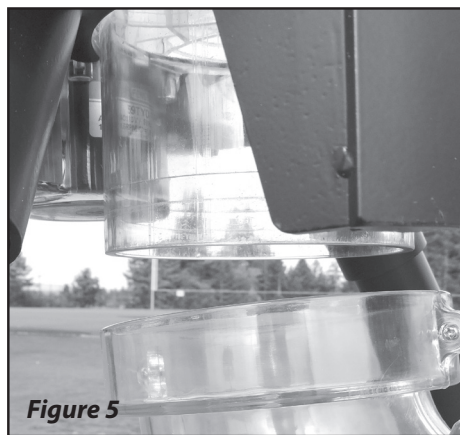
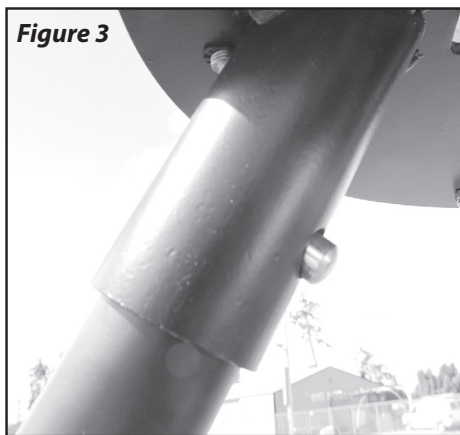

Figure 2a



JUGS mini3 SOFTBALL MACHINE SETUP—SIDE VIEW

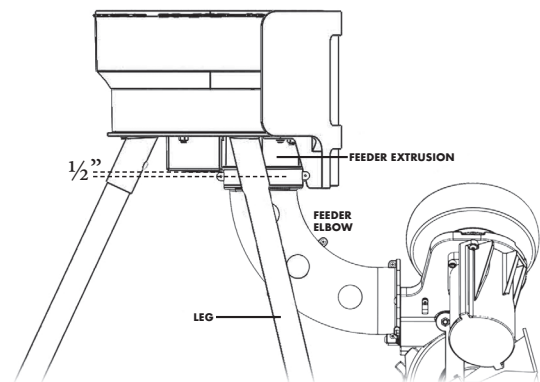
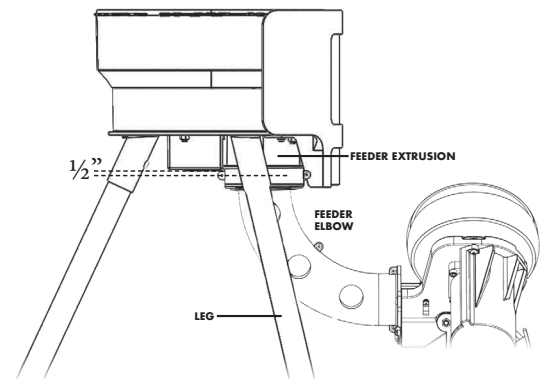

Figure 10

JUGS mini3 BASEBALL MACHINE SETUP—SIDE VIEW



JUGS SPORTS
11885 SW HERMAN RD., TUALATIN, OR 97062
1-800-547-6843 • jugssports.com